

Messenger™ Series ULT Freezer

The Covid-19 Vaccine Storage Solution

Total cold chain response from -86°C to +4°C

Messengers™ are the true portable ULT freezer solutions available today for bringing COVID vaccine at Ultra Low Temperature without risks.

Both Messenger 1 and Messenger 10 are perfectly sized, lightweight, and efficient portable -80 °C freezers ideal for clinical trials and biologic drug delivery.



- **Portable, reliable, continuous ULT operation**
- **Messenger 1 weights only 13.5 kg and can be shipped anywhere in the world by courier**
- **100% natural refrigerants.**
- **Piston Based Technology with no compressors no moving parts**
- **AC or 12-24 V DC outlet worldwide**

Compact, reliable, energy-efficient storage for cold-chain management, short-term or long-term ultra-low storage and transport of biological specimens.

New Messenger™ 10 Ultra Low Freezer

The ultra-low temperature Portable freezer is specially designed for Vaccine transportation. It is small in size, light in weight, and the lowest temperature can reach -80°C . It solves the industry's pain points in liquid nitrogen transportation and makes up for the shortage of liquid nitrogen transportation. The machine has a built-in large capacity lithium battery options available, which can be used to transport the vaccines without any external power source.

10L internal volume, temperature control accuracy $\pm 2^{\circ}\text{C}$, ultra-low temperature controlled mobile safe with adjustable temperature range from -80°C to 30°C , used to transport biological samples such as vaccines, bacterial viruses, bacterial viruses, blood, human organs, Immune medical products and other goods that have extremely high temperature requirements.

FEATURES

SAFETY

$\pm 2^{\circ}\text{C}$ temperature control accuracy of the whole box to avoid temperature fluctuation; NFX digital lock protects your samples in all aspects (this function is optional).

INTELLIGENT TEMPERATURE CONTROL

Sampling with laboratory grade PT100 thermo-sensor, ensuring temperature accuracy

DESIGN

Integrated high pressure foam, 20mm VIP (vacuum insulation panel), double layer submersible door, double layer sealing ring, ensure ultra-low thermal leakage, the lowest temperature can reach -80°C . Inside available volume is 10L, suitable for the transportation of vaccines. All metal integrated inside box, proprietary coating technology to ensure liner cleanness, test tube accessories, so that sample/vaccine temperature no longer fluctuates and transported safely.

COOLING SYSTEM

Advanced Stirling technology, using Stirling refrigerator as the core cooling source Ultra-low temperature, fast cooling and no fear of bumps and shakes, maintenance free life up to 50,000 hours

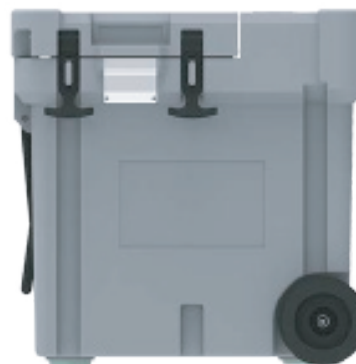
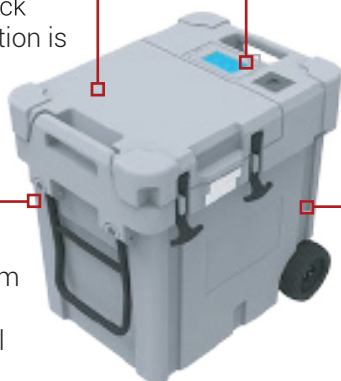

Part Number SL11670A

MIDSCI™
Laboratory Equipment & Supplies

ORDER TODAY! midsci.com • custserv@midsci.com • 800.227.9997 • f: 636.225.9998

Technical Specification

Messenger 10	
External Dimensions	615L x 462W x 625H mm
Internal Dimensions	227L x 292W x 155H mm
Capacity	10L
Weight	23 Kg (without battery)
Maximum Power	100W
Operating Voltage	12-24V
Rated Power	80W
Temperature Range	-80°C to 30°C
Built-in Battert	1/2/4/10 Hours (optional)

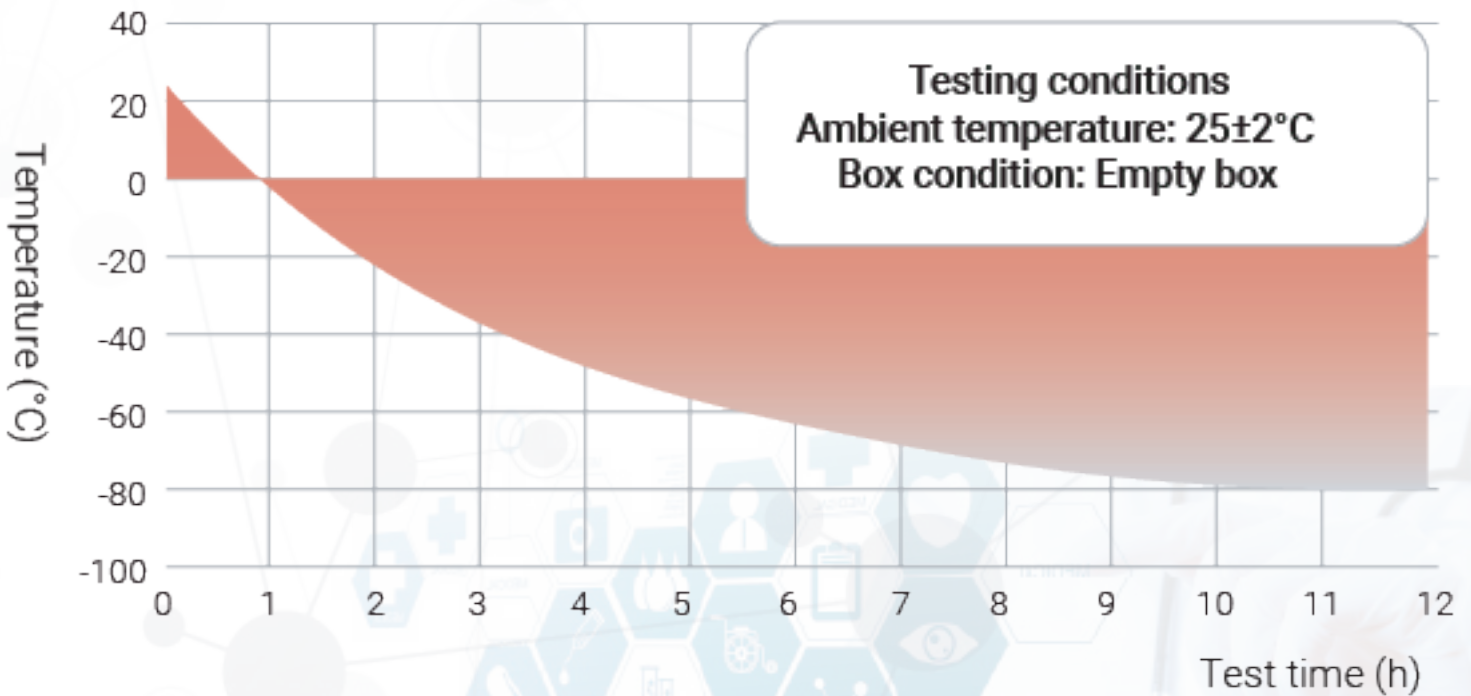
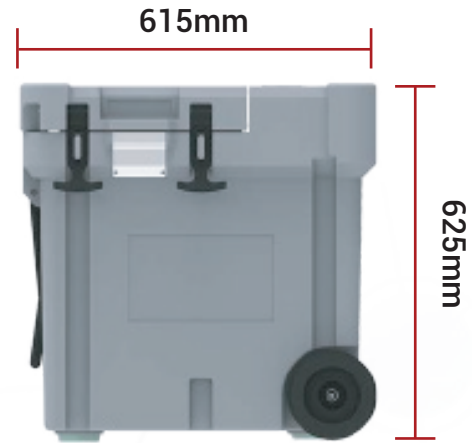

Part Number SL11670A

MIDSCI™
 Laboratory Equipment & Supplies

ORDER TODAY! midsci.com • custserv@midsci.com • 800.227.9997 • f: 636.225.9998

New Messenger™ 1 Ultra Low Freezer

Ultra-low Portable Freezer is specially designed for medical scenarios. It is small in size, light in weight, and the lowest temperature can reach -86°C . It solves the industry's pain points in liquids nitrogen transportation and makes up for the shortage of liquid nitrogen transportation. The machine has built-in large capacity lithium battery, which can work for more than 1 hour without external power.

1L internal volume, temperature control accuracy $\pm 0.5^{\circ}\text{C}$, with adjustable temperature range from -86°C to 4°C , used to transport biological samples such as vaccines, bacterial viruses, blood, human organs, immune medical products and other goods that have extremely strict temperature requirements.

FEATURES

SAFETY

$\pm 0.5^{\circ}\text{C}$ temperature control accuracy of the whole box to avoid temperature fluctuations; RFID digital lock protects your samples in all aspects (this function is optional)

DESIGN

Integrated high pressure foam, VIP (vacuum insulation panel), double layer submersible door, double layer sealing ring, ensure ultra-low thermal leakage, the lowest temperature can reach -86°C . 1L internal volume, standard 10x10 box, loading 100pcs of 2ml vials

INTELLIGENT TEMPERATURE CONTROL

PT100 thermo-sensor, ensuring temperature accuracy

COOLING SYSTEM

Advanced Stirling technology, using Stirling refrigerator as the core cooling source of Ultra – Low temperature, fast cooling and no fear of bumps and shakes, maintenance free life up to 50,000 hours



Part Number SL11670A

MIDSCI™
Laboratory Equipment & Supplies

ORDER TODAY! midsci.com • custserv@midsci.com • 800.227.9997 • f: 636.225.9998

Technical Specification

Messenger 10	
External Dimensions	270L x 270W x 450H mm
Internal Dimensions	150L x 134W x 54.5H mm
Capacity	1L
Weight	13.5 Kg
Maximum Power	100W
Operating Voltage	12-24V
Rated Power	80W
Temperature Range	-86°C to 4°C
Built-in Battert	≥1 Hour (Machine running at full power)

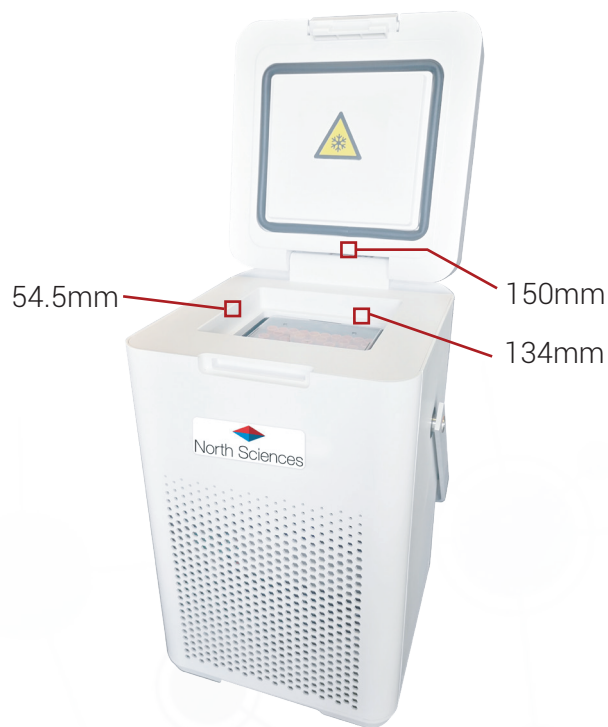

Product Performance

Ambient Temperature: 25°C
 Used Contents: 48* 1.8ml Test tubes
 Cooling time: 25°C to -86°C in 120min

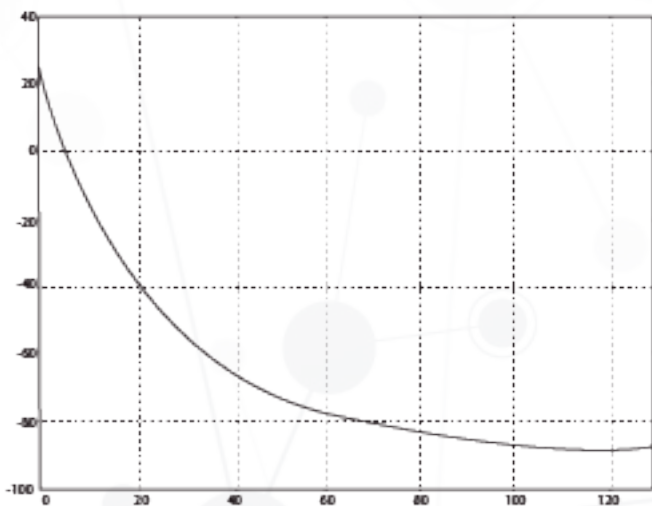

Put in 48* 1.8ml test tube (water filled), turn on the power and temperature reaches -86°C within 120 min

Ambient Temperature: 25°C
 Used Contents: 48* 1.8ml Test tubes
 Cooling time: 25°C to -86°C in 120min

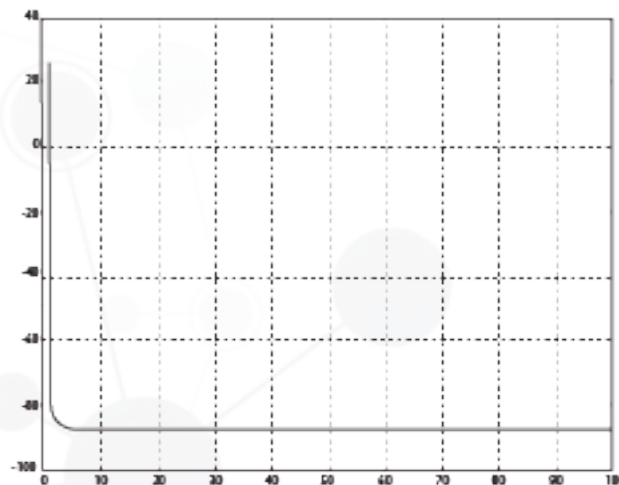

In operation state temperature is -86°C, Put in 48x1.8ml test tube (water filled) in freezer and the sample temperature reaches -86°C within 2.5min

Part Number SL11670A

MIDSCI™
 Laboratory Equipment & Supplies

ORDER TODAY! midsci.com • custserv@midsci.com • 800.227.9997 • f: 636.225.9998